

TO SUIT SM2 TYPE KERB

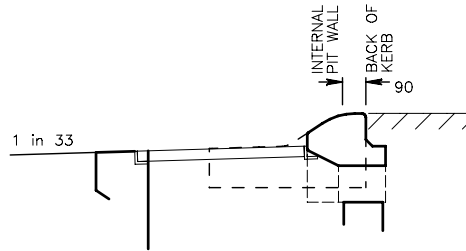

TO SUIT SM3 TYPE KERB

NOTES

- Open weave grate shall be:
 - bicycle safe
 - non-clogging
 - Hydraulic performance > 50%
 - conforming to AS 3996 (Class D)
- Grate and surround to be hot dip galvanised.
- Allowable tolerance between grate and surround to be 5 mm MAX.

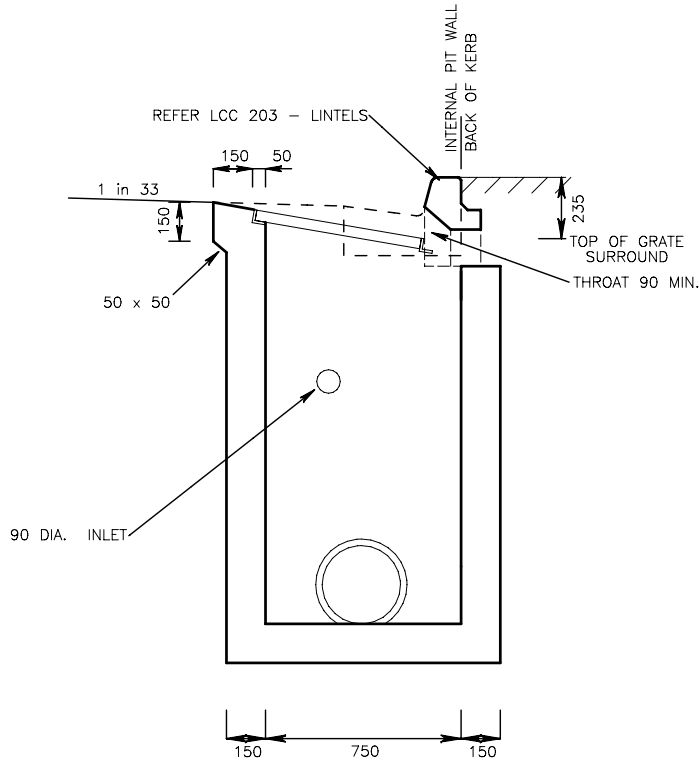

SECTION TO SUIT B2 TYPE KERB

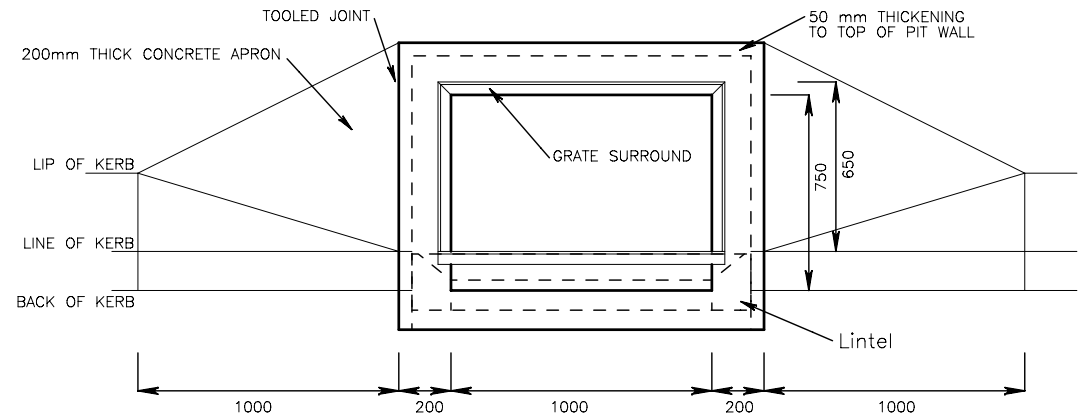

PLAN

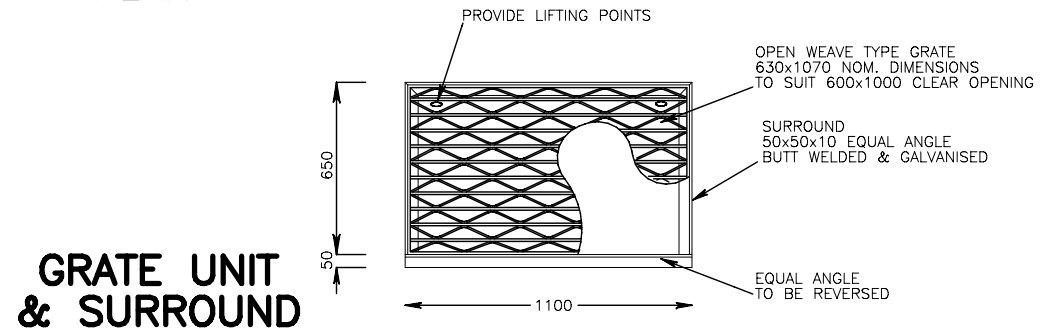

GRATE UNIT & SURROUND



GENERAL NOTES / CROSS REFERENCES

- All dimension in mm unless noted otherwise.
- Refer to pit schedule for individual pit sizes.
- Concrete strength shall be as specified.

Latrobe City

GRATED SIDE ENTRY PIT

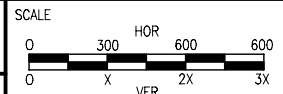

DWG No. **LCC 206**

CITY AUTHORISATION

VERSION/ DATE OF PLOT 23/08/2010

SHEET NO. 1 OF 1