

TYPE A1 – JUNCTION PIT  
PRECAST CONCRETE LID & SURROUND

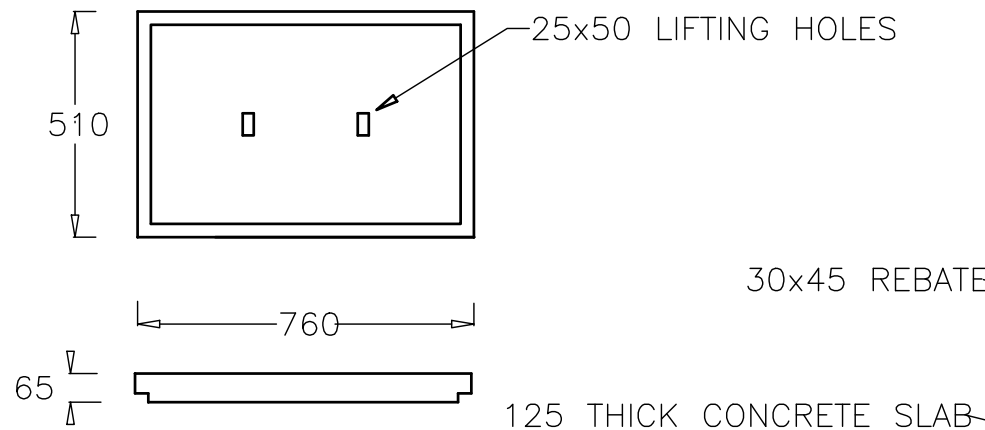

\*NOTE: TYPE A COVERS SHALL TEST LOAD TO 100kN min

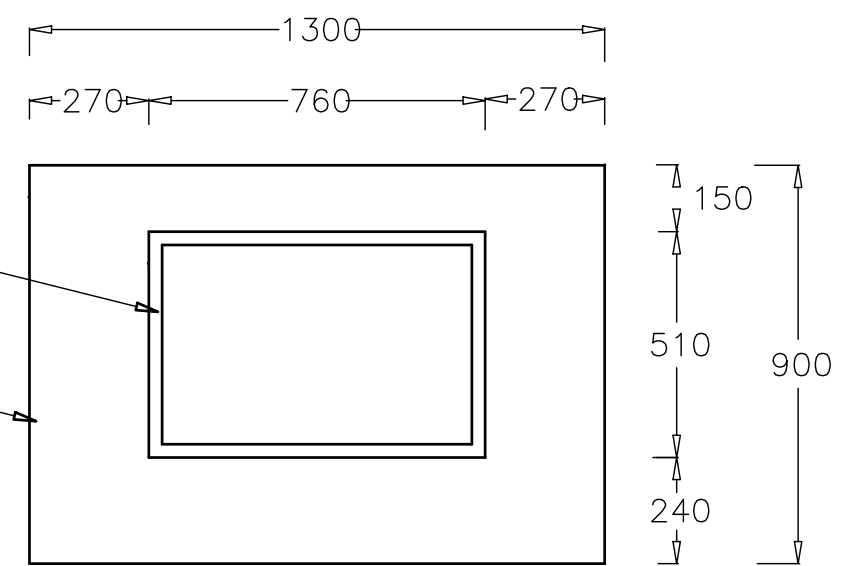

TYPE A2 – SIDE ENTRY PIT  
PRECAST CONCRETE LID & SURROUND

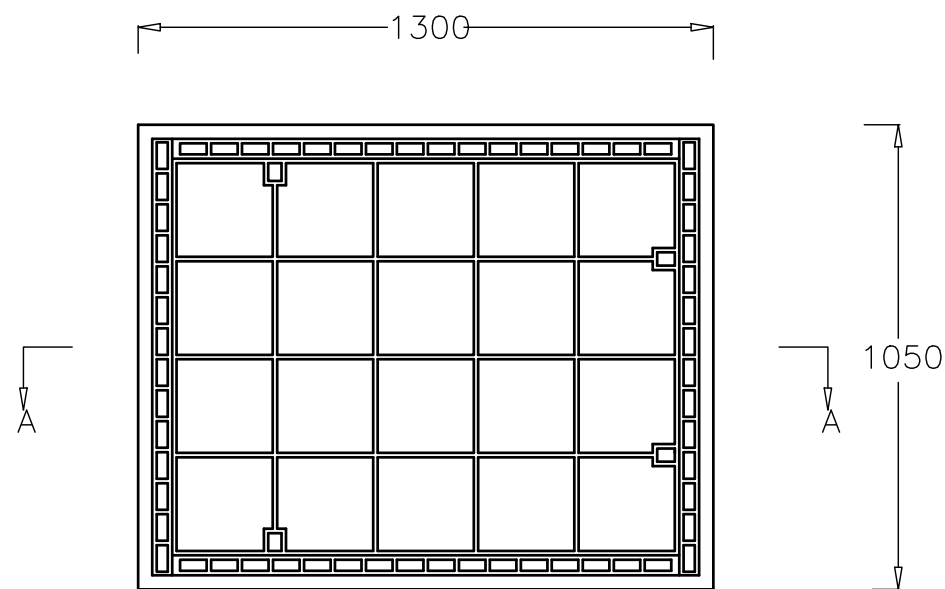

TYPE B – JUNCTION PIT  
CONCRETE INFILLED CAST IRON COVER & FRAME

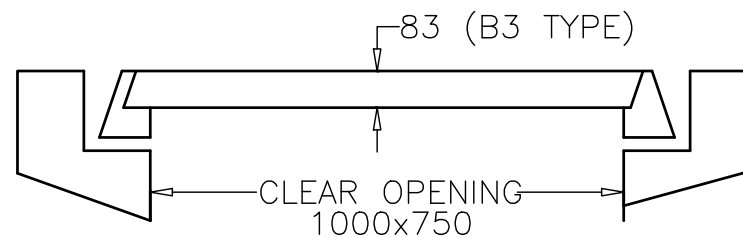

SECTION A-A

\*NOTE: TYPE B3 SHALL TEST LOAD TO 210kN min



GENERAL NOTES / CROSS REFERENCES

1. All dimensions in mm unless noted otherwise.
2. Chamfers are 15 x 15 unless shown otherwise.
3. Concrete strength shall be as specified.

File name:

**Latrobe City**

PIT COVERS

SCALE

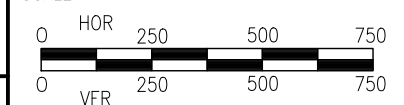

DWG No.

LCC 202

SHEET NO. 1 OF 1

CITY AUTHORISATION

VERSION/  
DATE OF PLOT 27/5/2021